

REV.	DESCRIPTION	DATE
A	REDESIGNED	14APR.03

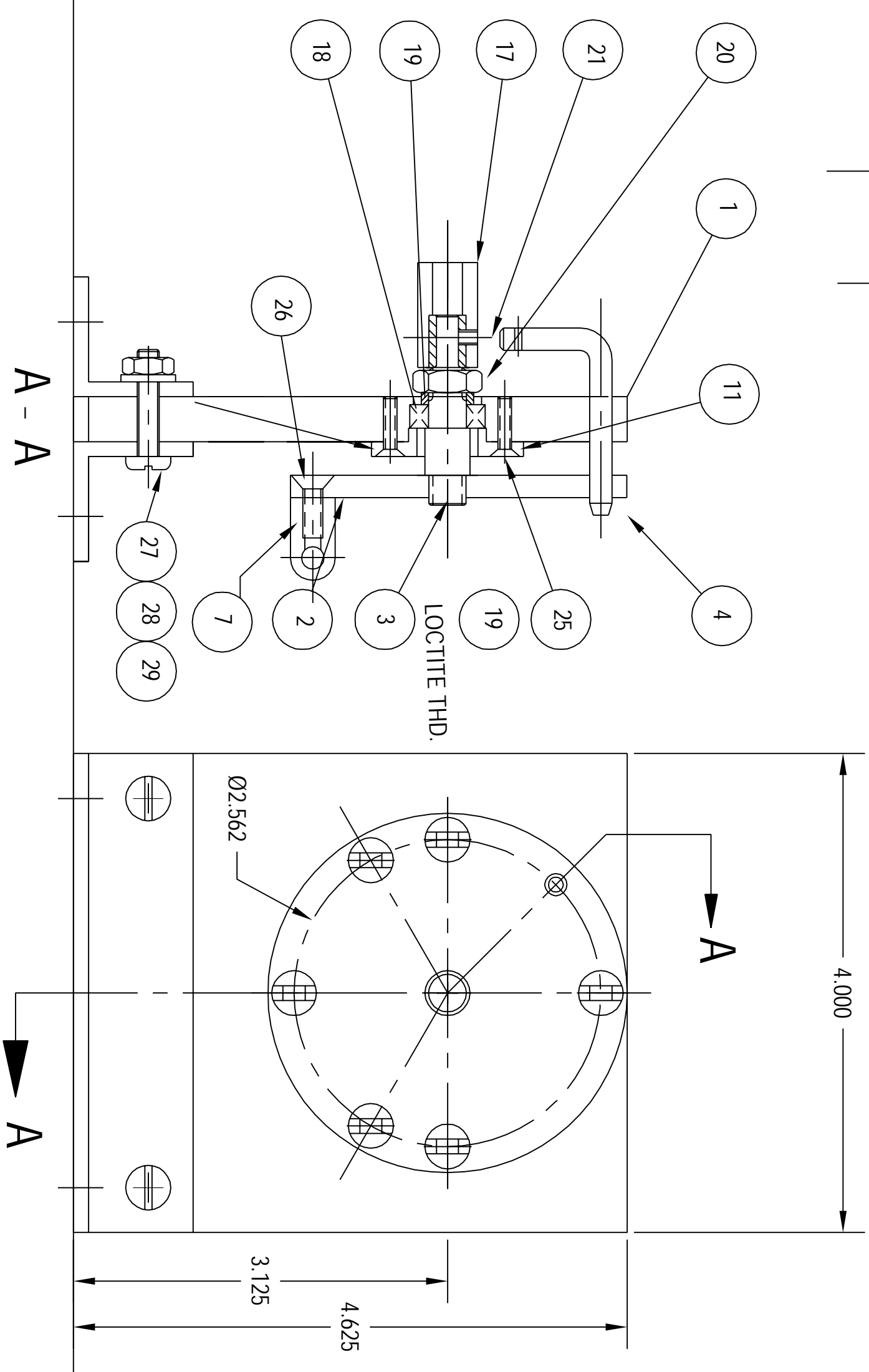

LOOPER

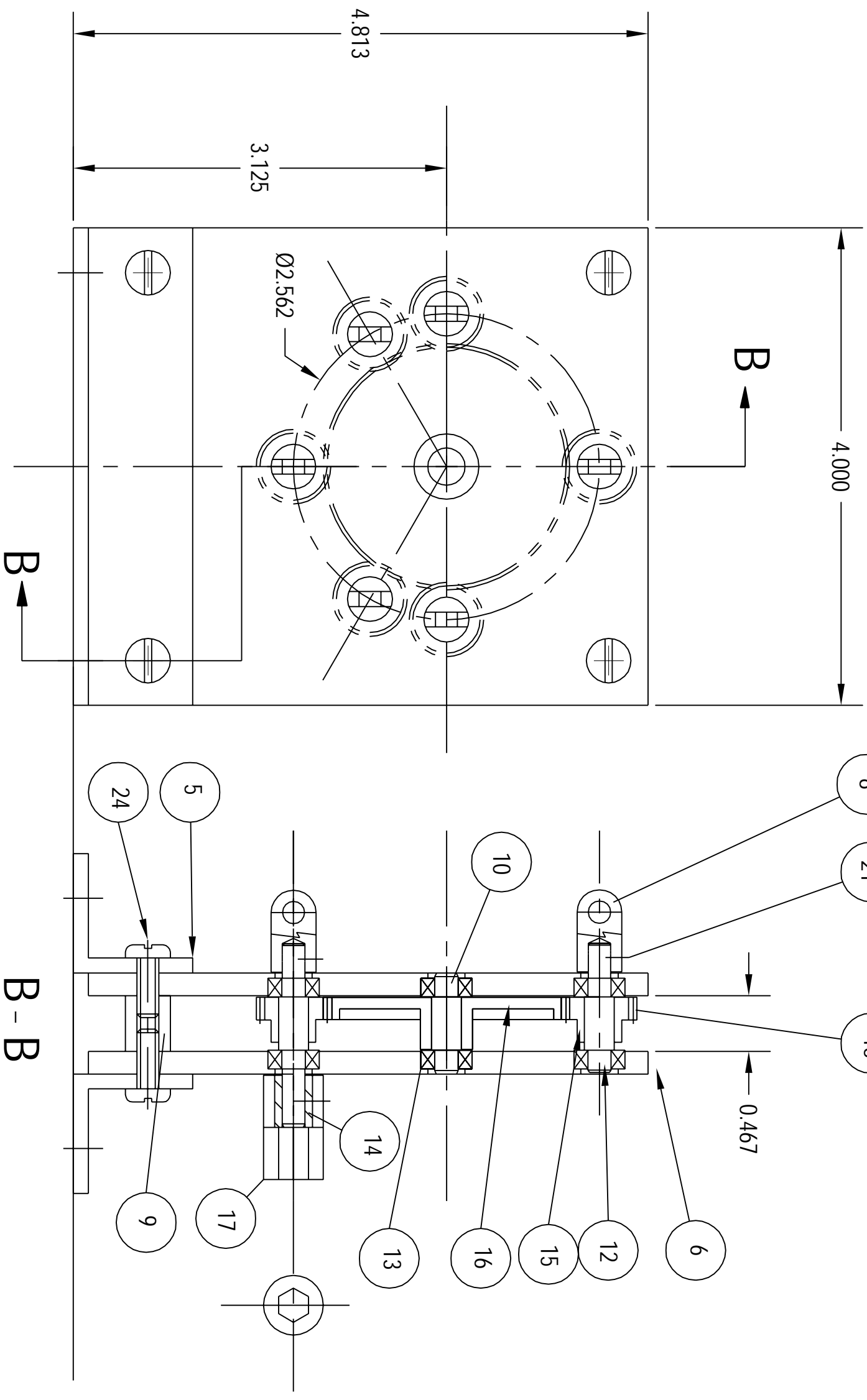

WHIRLS

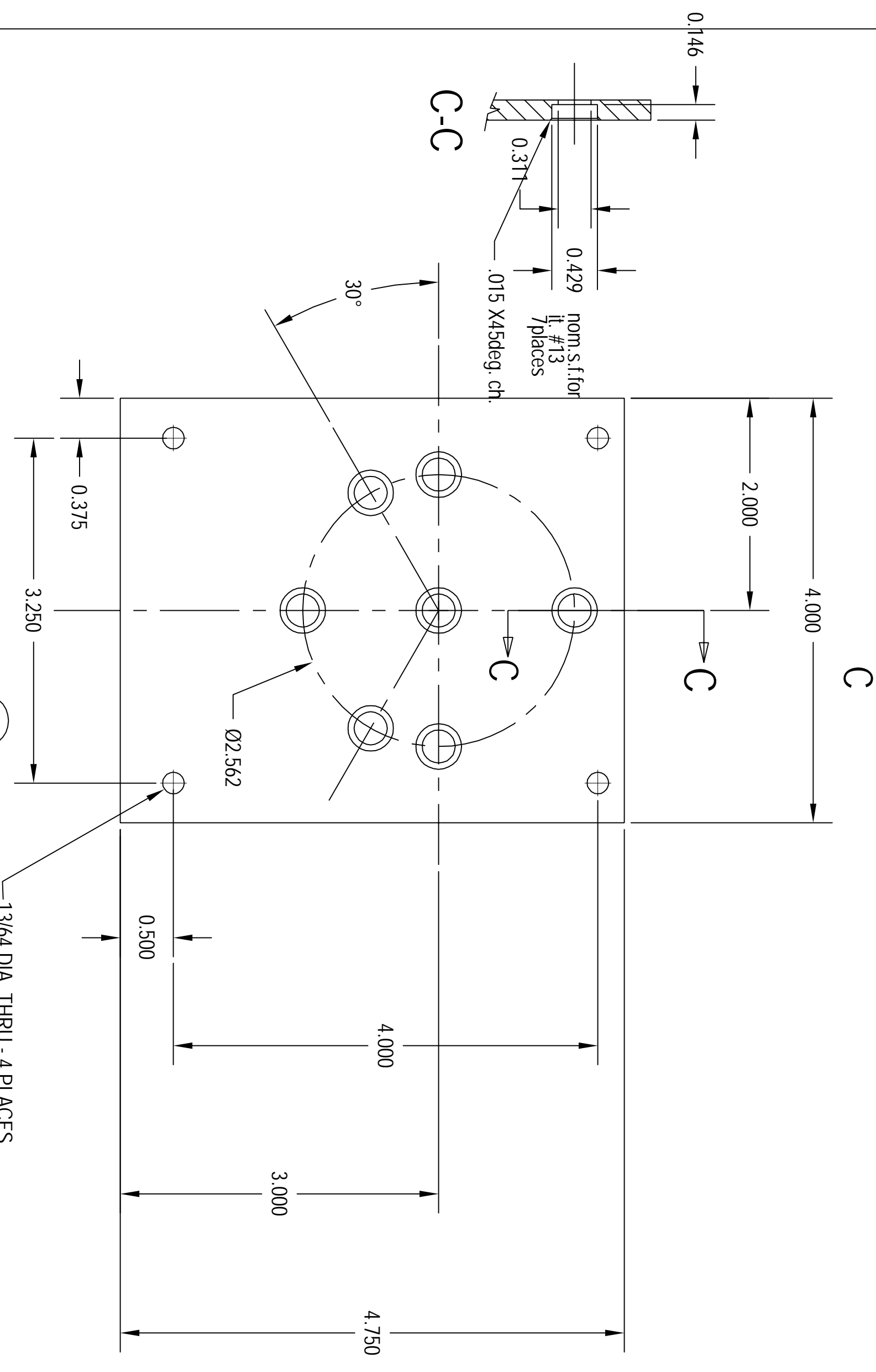
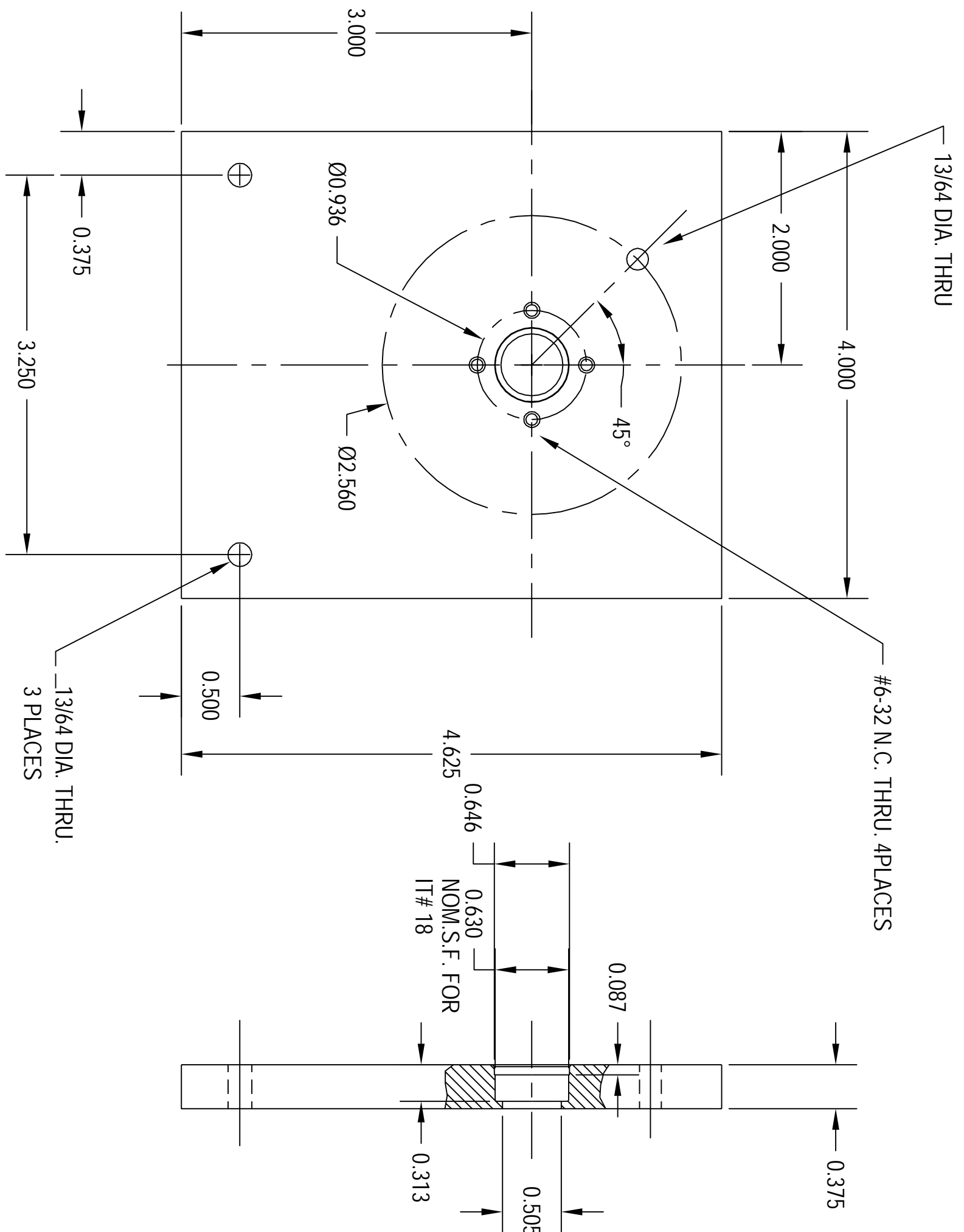

SEE NOTE 1.

29	2	PLAIN WASHER	#8	STL.
28	2	HEX. NUT	#8-32 N.C.	STL
27	2	PAN HD. MACH. SCR.	#10-24 N. C. X 7/8	STL.
26	6	FLAT HD. MACH. SCR.	#8-32 N.C. X 1/2	STL.
25	4	FLAT HD. MACH. SCR.	#6-32 N.C. X 1/2	STL.
24	8	PAN HD. MACH. SCR.	#10-24 N.C. X1/2	STL.
23				
22				
21	8	SETSCREW	#5-40 N.C. X 3/16	STL.
20	1	HEX JAM NUT	5/16-18N.C.	STL.
19		SPACER	7/16 DIA. X 1/8	
18	1	BALL BEARING	(SEE NOTE 2)	STL.
17	2	HEX. HOLED SLEEVE	A-1000132 (1 makes 2)	C.R.S.
16	1	GEAR 64T	GC 644 (SEE NOTE 4)	DEL RIN
15	6	GEAR 18 T	GC 184 (SEE NOTE 4)	DEL RIN
14	2	SLEEVE	5/160D X 3/16ID X 7/16	STL.
13	14	BALL BEARING	(SEE NOTE 3)	STL.
12	6	PIN	1/4 DIA. X 1 3/32	C1020
11	1	RETAINING RING	9/32 X 1 1/4 DIA.	ALUM.
10	1	PIN	1/4 DIA. X 7/8	C1020
9	4	SPACER	3/8 DIA. X 15/32	C1020
8	6	POST	3/8 DIA. X 11/16	C1020
7	6	POST	3/8 DIA. X 11/16	C1020
6	2	PLATE	3/16 X 4 3/4	ALUM.
5	4	ANGLE	1 X 1 X 1/8 X 4	ALUM.
4	1	LOCK PIN	3/16 DIA. X 2 1/4	C 1020
3	1	SHAFT	3/8 DIA. X 1 9/16	C 1020
2	1	DISC	3/16 X 3 DIA.	ALUM.
1	1	PLATE	3/8 X 4 X 4 5/8	ALUM.

DWG. TITLE:

ROPE WALK ASSY. & DETAILS

DRAWN	DATE	SCALE	DWG. NO.	REV
K.H.	OCT. 2002	FULL	1022 SHT. 1 OF 2	A

- NOTES.**
- THIS PART IS SOLD BY SMALL PARTS INC. 13980 N.W. 58TH COURT. P.O. BOX 4650. MIAMI LAKES, FLORIDA 33014-0650. TEL. 1-800-220-4242.
 - IT #18 IS 8 X 16 X 6MM DOUBLE SHIELDED AVAILABLE FROM HOBBY RACE CAR STORES
 - IT #13 IS 5 X 11 X 4MM DOUBLE SHIELDED AVAILABLE FROM HOBBY RACE CAR STORES.
 - THESE PARTS ARE PURCHASED FROM SERV-O-LINK CORP.
 - SEE DWG.# 1022 SHEET 2 FOR FURTHER DETAILS.